

Lower Owning and Operating Costs—Maximum Productivity

The 450 Series II sets a new standard in the 45 ft. (13.7 m) articulating boom lift class. The increased work envelope benefits operators on both jib and non-jib models. Plus, the 450 Series II features JLG's exclusive Control ADE™ (Advanced Design Electronics) system which provides enhanced performance and serviceability.

Maximum Productivity

Productivity on the job is vital and the 450 Series II is up to the task with increased rough terrain performance and industry leading duty cycles.

- 45% gradeability on 4x4 models reflects true jobsite performance
- The Control ADE system provides better fuel efficiency to lower costs and increase uptime
- Standard articulating jib on the 450AJ increases access in confined spaces

Designed to keep the machine where it belongs—on the job

The electrical and hydraulic systems have been enhanced to eliminate complexity and reduce service.

- The Control ADE system has minimized the number of wires and connections
- The hydraulic system has been redesigned to eliminate hose wear and minimize maintenance—hoses have been reduced by 250 ft.
- The new tower boom provides elevation that makes the operator feel more at home in the sky

Operator Preferred Controls now with Control ADE

- The Control ADE system links the 450 Series II to other combustion-powered boom lifts, reducing the need for repeated service training
- The control layout provides operation uniform to other JLG boom lifts
- Heavy duty cast aluminum control box is JLG's answer to jobsite abuse



www.jlg.com

450 Series II

ARTICULATING BOOM LIFTS



JLG

JLG MODEL 450 SERIES II

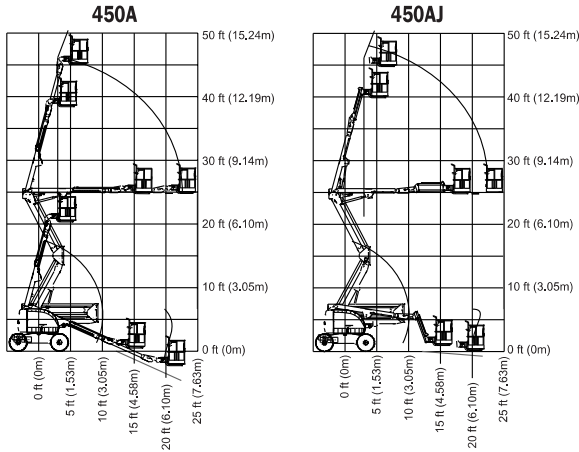

REACH SPECIFICATIONS

Platform Height	45 ft. (13.72 m)
Horizontal Outreach	24 ft. 6 in. (7.47 m)
Up and Over Height	25 ft. 2 in. (7.67 m)
Swing	360 Degrees Non-Continuous
Platform Capacity—Unrestricted	500 lbs. (227 kg)
Platform Rotator	180 Degrees Hydraulic
Jib - 450AJ Only - (Range of Articulation)	4 ft. 1 in. (1.24 m)
	145 Degrees (+78, -67)

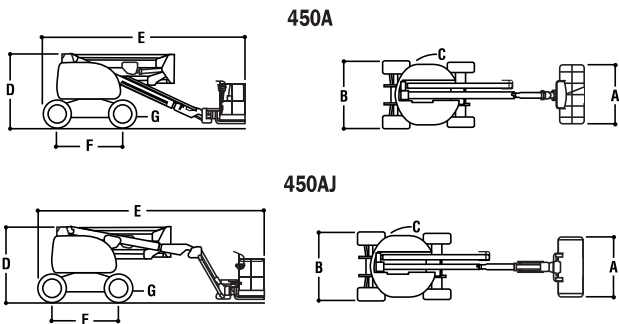

DIMENSIONAL DATA

A. Platform Size	30 x 72 in. (0.76 x 1.83 m)
B. Overall Width 2WD	6 ft. 6 in. (1.98 m)
Overall Width 4WD	6 ft. 10 in. (2.08 m)
C. Tailswing (working condition)	Zero
D. Stowed Height	7 ft. 5 in. (2.26 m)
E. Stowed Length	21 ft. 5 in. (6.53 m)
F. Wheelbase	6 ft. 6 in. (1.98 m)
G. Ground Clearance	14 in. (36 cm)
Gross Vehicle Weight (450A)	14,500 lbs. (6,577 kg)
Gross Vehicle Weight (450AJ)	16,500 lbs. (7,484 kg)
Max. Ground Bearing Pressure 2WD	58 psi (4.06 kg/cm ²)
Max. Ground Bearing Pressure 4WD	35 psi (2.5 kg/cm ²)

CHASSIS

Drive Speed 2WD	3.5 mph (5.6 kph)
Drive Speed 4WD	4.5 mph (7.2 kph)
Gradeability 2WD	30%
Gradeability 4WD	45%
Tires 2WD	12 x 16.5 Lug Tread
Tires 4WD	33/1550 x 16.5 Superwide
Axle Oscillation	8 in. (20.3 cm)
Turning Radius, (Inside/Outside)	5 ft. 8 in./14 ft. (1.73 m/4.27 m)

POWER SOURCE

Dual Fuel Engine, Ford LRG-425	82 hp (61 kW)
Diesel Engine, Deutz F3M1011	47 hp (35 kW)
Diesel Engine, Caterpillar 3024C	50 hp (37.2 kW)
Fuel Tank Capacity	16.5 gal. (62.5 L)
Hydraulic Reservoir	30 gal. (113.6 L)
Auxiliary Power	12V DC

PERFORMANCE FEATURES

Standard Features

- 2 Year Extended Limited Warranty
- 4 ft. (1.22 m) Articulating Jib (450AJ only)
- Platform 30 x 72 in. (0.76 x 1.83 m) Side Entry
- Inward Self-Closing Swinging Gate
- 180 Degree Hydraulic Platform Rotator
- Platform Console Machine Status Light Panel*
- 110V-AC Receptacle in the Platform
- 5 Degree Tilt Alarm/Indicator Light
- Rim Protector Lug Tread Tires
- Swing Out Engine Module
- Gull-wing Turntable Hoods
- 12V-DC Auxiliary Power
- Hourmeter
- Hydrostatic Drive
- Proportional Controls
- Control ADE™ System
- Lifting/Tie Down Lugs
- Horn
- Oscillating Axle
- Aluminum Cast Control Box
- Operator Tool Tray
- Motion Alarm

*Provides indicator lights at platform control console for system distress, low fuel, 5 degree tilt light, and foot switch status.

Available Options

- 30 x 60 in. (0.76 x 1.52 m) Platform
- Mesh to Top Rail - Bolt-on Aluminum
- ½ in. Air Line to Platform
- Platform Work Lights
- Soft Touch System
- Foam-Filled Tires
- Non-Marking Tires
- 2500W Generator
- Flashing Amber Beacon
- Remote Swing Bearing Lube Fitting
- 43.5 lbs. (19.73 kg) Propane Tank
- Cold Weather Kit¹
- Hostile Environment Kit²
- Semi-Trak
- Light Package

1. Includes battery blanket, hydraulic tank heater, block heater (Ford and CAT), glow plugs (Deutz and CAT)

2. Includes boom wipers, cylinder bellows and console cover.

Note: Some options may increase lead time, and some option combinations may not be available.

The JLG "2 & 5" Warranty for Models 450A & 450AJ

JLG Industries, Inc. backs our 450 Series II boom lifts with our exclusive "2 & 5" Warranty. We provide coverage for two (2) full years, and cover all specified major structural components for five (5) years. These machines meet or exceed applicable OSHA Regulations in 29 CFR 1910.67, 29 CFR 1926.453, ANSI A92.5-1992 and CSA standard CAN3-B354.4-M82 as originally manufactured for intended applications. We reserve the right to make price, specification, and/or equipment changes without prior notification. All prices are in U.S. dollars, ex-works McConnellsburg, PA.

JLG Industries, Inc.

1 JLG Drive, McConnellsburg, PA 17233-9533
 Telephone 717-485-5161 Toll-free in US 877-JLG-LIFT
 Fax 717-485-6417
 www.jlg.com

Printed in USA
 FORM NO.: SS-450II-1001-10M
 PART NO.: 3131117
 R010401

